

Electrical Test:

1. 100% Test(Open ,short ,miss wire)
2. Contact Resistance: 3 ohm max.
3. Speed 500MB/S

Pin Assignment

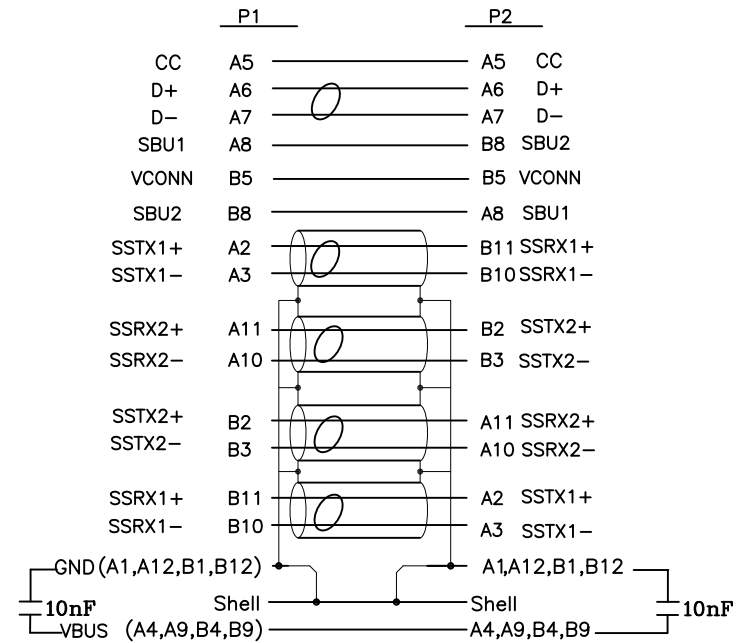

7	Type C Metal DOWN Cap	2	pcs						
6	Type C Metal UP Cap	2	pcs						
5	Outside Molding:45P PVC Color:Black	17	g						
4	Inside Molding:Polyamide Resin	1.0	g						
3	USB3.1 Type C Connector Shell Nickel Plated With PCB+SMT	1	pcs						
2	USB3.1 Type C Connector Shell Nickel Plated With PCB+SMT~EMARK	1	pcs						
1	USB3.1~[30AWG(7/0.105TC)+EAM]*4P+[32AWG(7/0.08TC)+AM]*1P+34AWG(7/0.06TC)*1C+26AWG(19/0.10TC)*2C+[34AWG(7/0.06TC)+A]*3C+A2EB(24/11/0.06TC 90%)OD:5.2MM~PVC Black Marking:E342987 兄 AWM STYLE 2725 80°C 30V VW-1	AR	m						
NO	DESCRIPTION	Q'TY	UNIT						

		TOLERANCE		
		INCHES	M/M	
.X		.015	.30	
.XX		.010	.10	
.XXX		.005	.05	

TITLE: VALUE USB3.1 Cable, PD 20V5A, C-C, M/M, 1m Black

DRAWN BY	QJL	Item No.:	11.02.9053
CHECK BY		SCALE	NONE
APPD BY		UNIT	MM
		DATE	2018.06.25

DRAWING NO.:		REV.	AO1
			1/1